

Acid and Base

Experiment 1: Making and using of Plant Indicator

Materials: Eggplant (Baingain), red cabbage, alum (phatkari, Sulfate Aluminum potassium), filter paper, sprit lamp, knife, vinegar, HCl, NaOH

Procedure:

Extraction of coloring matter

- (1) Peel off the outer skin as thin as possible.
- (2) Cut it into small pieces and place in a 100 ml beaker.
- (3) Add 20 ml tap water to the skin.
- (4) Boil for about 5minutes.
NOTE: The extract gets spoiled if it is left for more than 5 minutes.
- (5) Immediately add a pinch of alum powder (2-3 match heads) or until the solution becomes dark blue in color. Stir it well.
- (6) Keep the solution in a covered bottle.

How to use:

- (1) Take the strong acid solution (HCl solution) , weak acid(vinegar), neural(tap water), weal alkaline solution(soap solution) and strong alkaline solution(NaCl solution) in separate glass tubes.
- (2) Add 10 drops of the indicator to the first test tube. Shake the test tube well.
- (3) Observe the color change.
- (4) Do the same to the succeeding test tubes.

Concept:

The red and blue colors of most flowers and some vegetables are due to a group of organic substances known as anthocyanins. This natural indicator is extracted from alcohol or water. It can be used an acid-base indicator.

Materials	PH	Nature of sample	Color of indicator
HCL solution	About 1	Strong acid	
vinegar	2-3	Weak acid	
Tap water	About 7	neutral	
Soap solution	About 10	Weak base	
NaOH solution	13-14	Strong base	

Experiment C4-2: Movement of ions

Materials: connecting wire (2), 9V dry cell, eggplant indicator, paper clips, tissue paper, plastic cup, HCl, NaCl, thread, glass slide, straw

Procedure:

- (1) Cut one sheet of tissue paper and fold it thrice to the size of the glass slide (2.5cm × 7.5cm), Cut the excess paper.
- (2) By using a straw, add the eggplant indicator over the entire area of the paper on the glass slide. (Note: The paper should not be too wet)
- (3) Attach a paper clip to each end of the plate.
- (4) Connect the setup to a 9V dry cell.

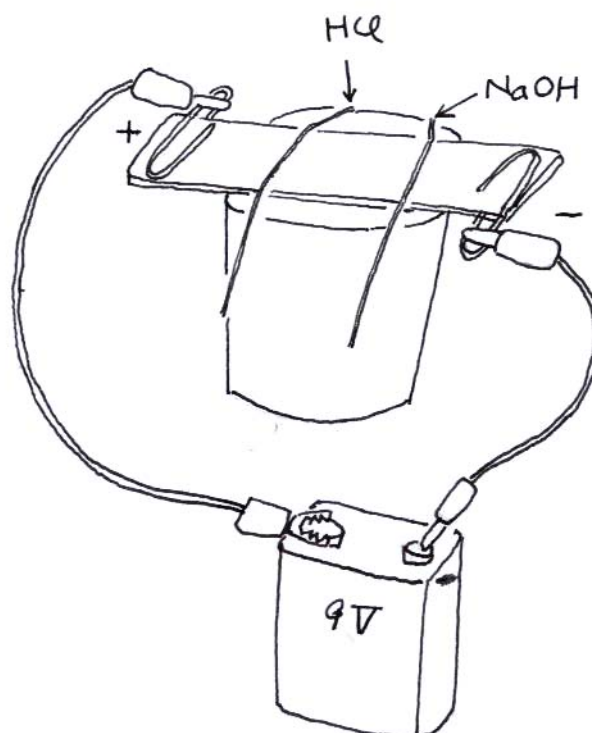

- (5) Soak a piece of thread (6cm) thoroughly in 1M HCl, then press the thread carefully across the paper with the current on. Soak another piece of thread (6cm) in 1M NaOH and place it on the same paper 2-3cm apart.
- (6) Observe the area in which an apparent movement took place after 15 minutes.

Question:

- (1) Describe what you observe after 15 minutes.
- (2) Explain why the colored band spreads toward the negative electrode: and toward the positive electrode.